

PCB Inspection System
Model: VT-S1080/S1040/Z600

OMRON

Innovating manufacturing through unique technology High-quality, high-reliability AOI



Working together with our customers to create a better manufacturing environment

ADAS, automated driving, EVs, 5G... The technological evolution of the market has made manufacturing demands more complex and diverse, with higher quality requirements. At the same time, labor shortages are only adding to these challenges. There is an urgent need to not only increase equipment and improve performance, but also develop and train a skilled workforce able to support production. In order to respond to these trends, Omron Inspection Systems Division is committed to:

- Zero defect products through reliable, high-precision inspection
- Minimizing programming time and skill through AI and quantitative inspection
- Maximizing good-quality throughput to prevent defects through the utilization of accurate quality data from inspection equipment alongside manufacturing data

Trends of manufacturing environment

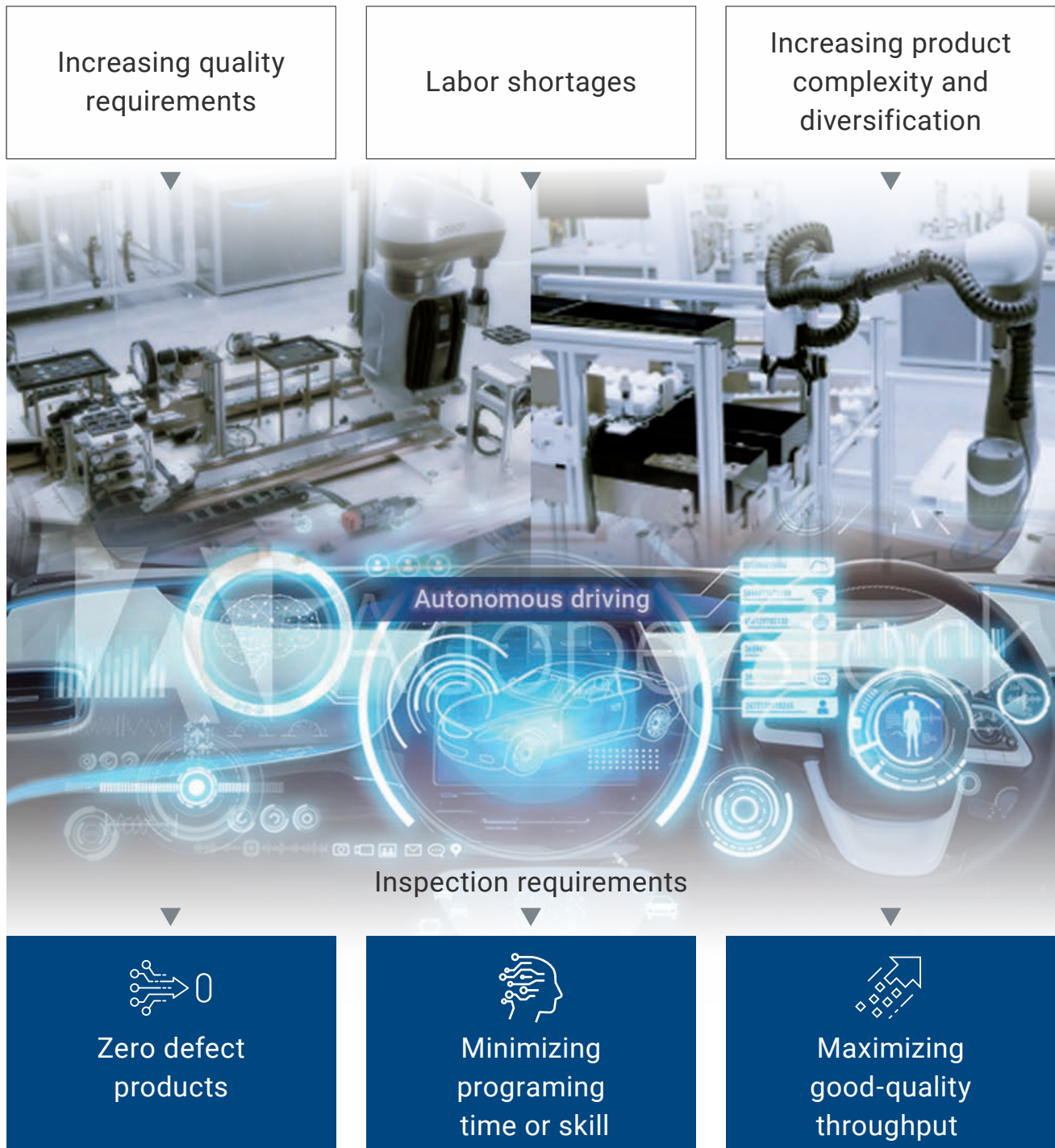

Omron's unique technology achieves the inspection requirements

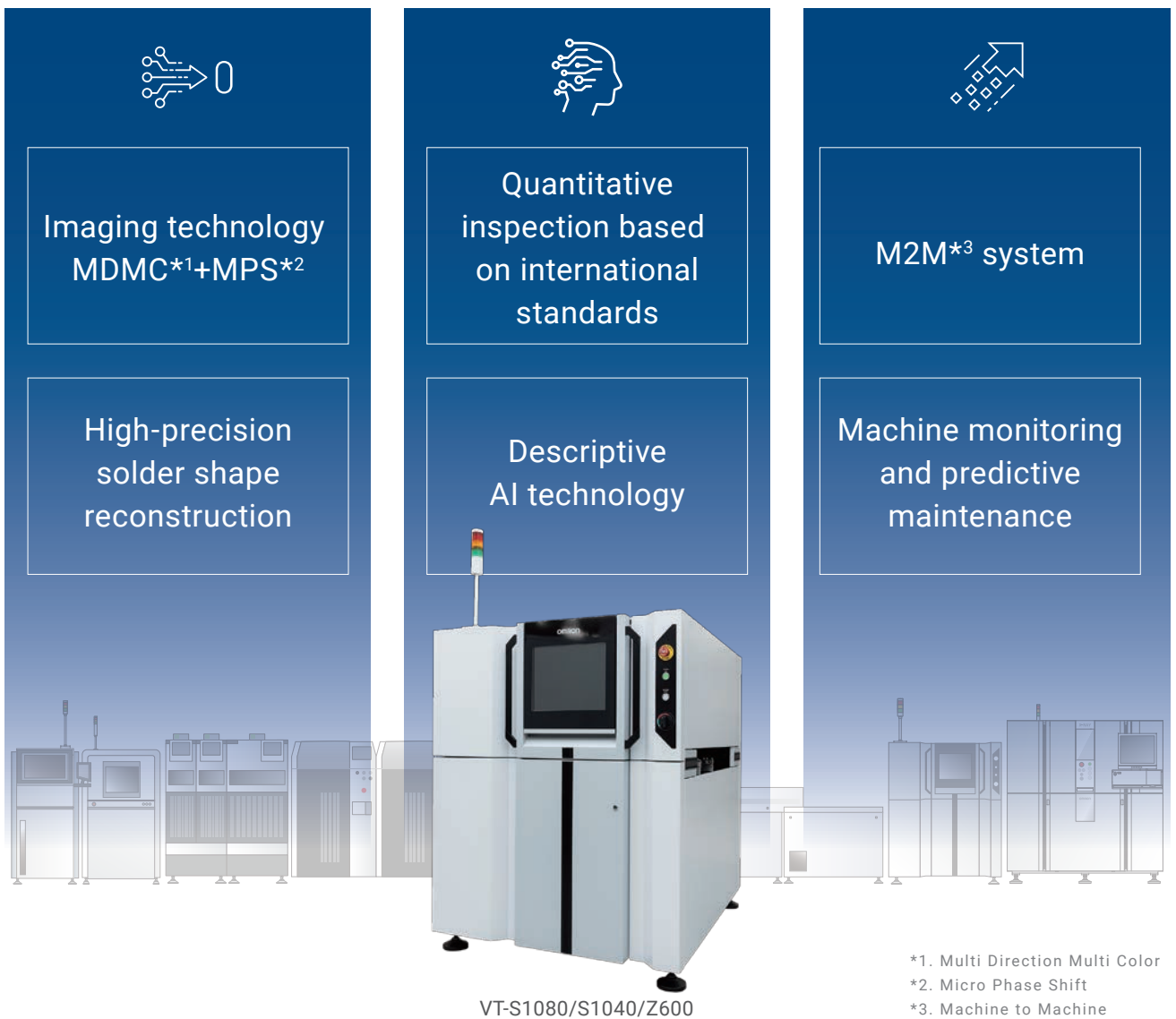

VT-Z/S series, common platform AOI

Flexible machine solutions that are field upgradable*4, able to share programs and available in single or dual lane configurations*5.

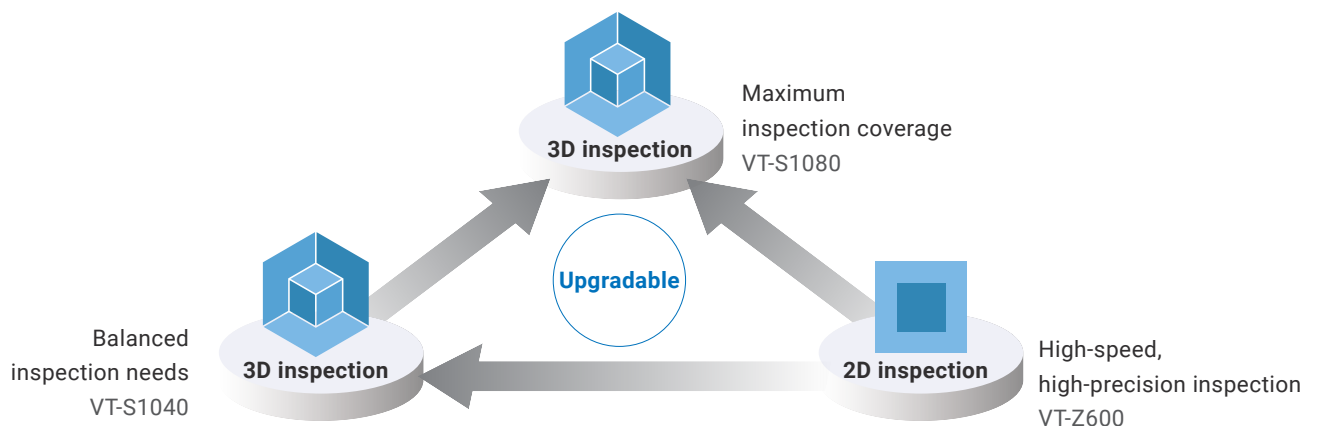

*4. Under development. *5. Single or dual lane option is only selectable upon initial order.

High-precision solder shape reconstruction helps achieve zero defect products

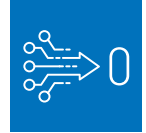

Omron's own MDMC illumination and MPS

Equipped with Omron's own MDMC (Multi Direction/Multi Color) illumination and new MPS (Micro Phase Shift) moiré technique, the system achieves highly robust*6 and reliable inspection performance.

Patented

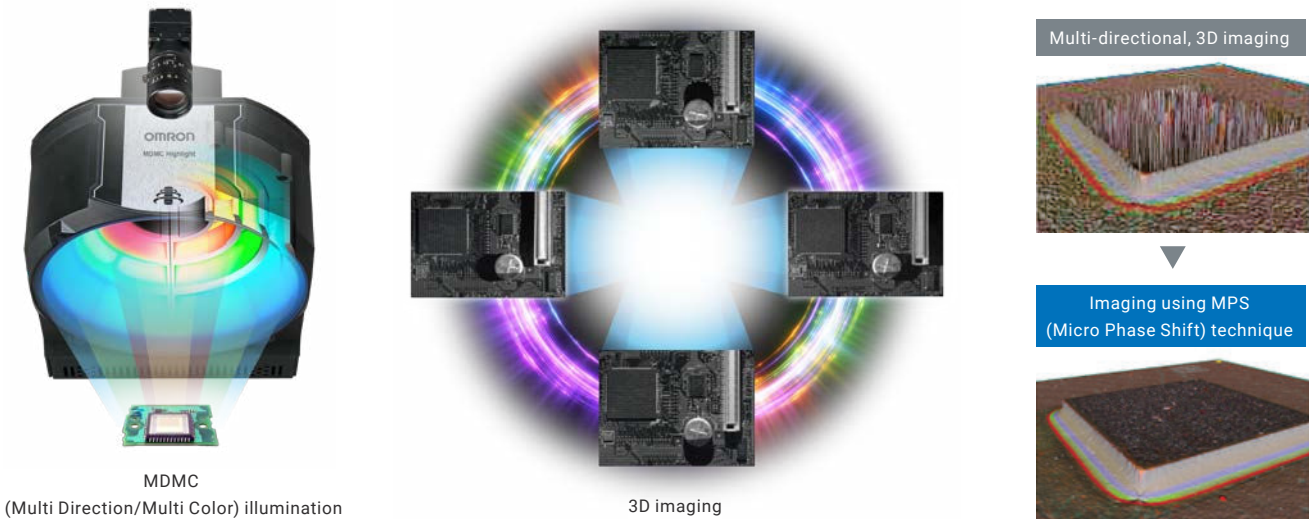

*6. Strong against noise that effects the judgement of inspection results such as shadows, secondary reflections, abnormal defect shapes and other uncertain factors.

High-precision solder shape reconstruction

Omron AOI technology combines precise imaging with advanced data processing to yield accurate and stable solder shape profiles.

Reduces the noise caused from secondary reflections

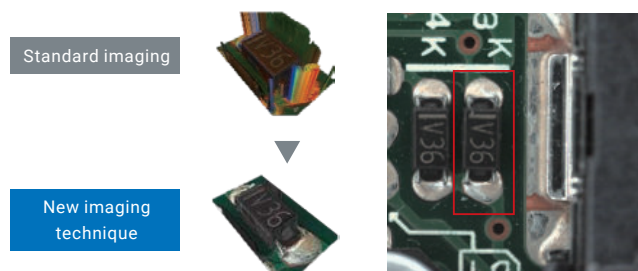

Reduces the effect of shadows from large parts

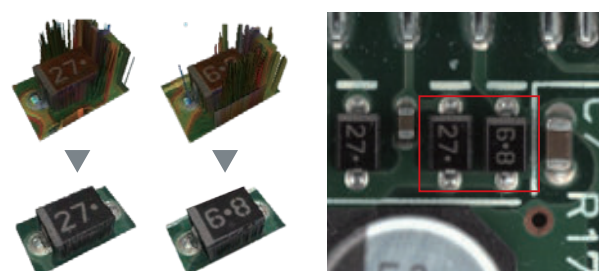

Allows stable inspection of fine parts

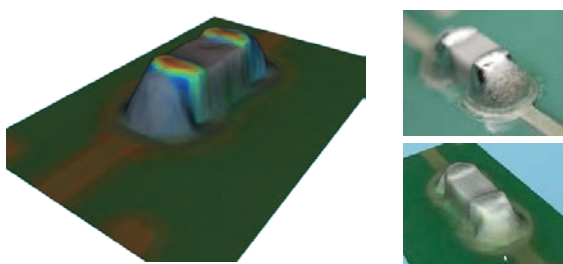

Visibility even at the connector solder joint

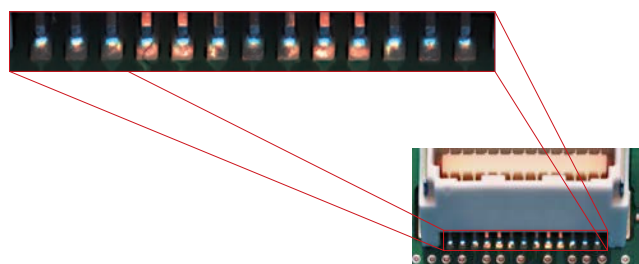

Example images from test results of customer products

Minimization of programming efforts by quantitative inspection and AI-assisted qualitative inspection



Quantitative inspection conforming to international standards*7

Since values conforming to the standards are directly applied as inspection criteria, there is no dependency on the skill and expertise of the programmer.

Setting thresholds

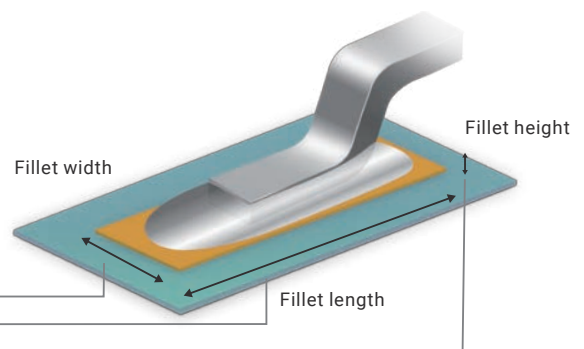
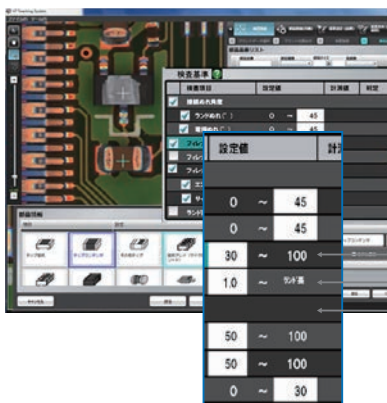

*7.IATF (ISO/TS) 16949, IPC quality standards, etc.

Descriptive AI technology

Omron is developing a variety of reliable AI tools to address customer concerns such as defects going undetected and/or managing large amounts of machine learning data when using AI for inspection.

*AI is option

Automatically acquire defect images for analysis



Visualization of result data separation for AI-assisted defect determination

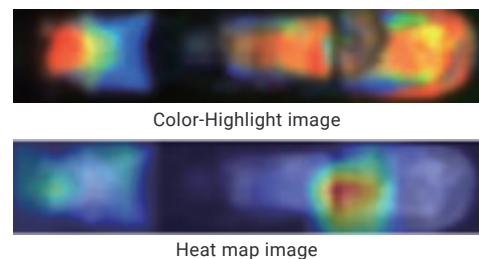

Visualization of the AI-determined settings

	OK judgement	NG judgement	Over-reject/Escapes rate
OK data	193 (193)	0 (0)	0.0000%
NG data	0 (0)	48 (48)	0.0000%
Gray data	0 (0)	0 (0)	

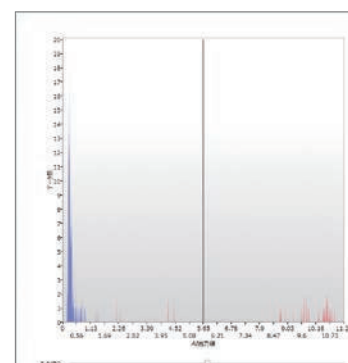

Maximizing good-quality throughput by using quality focused, M2M communication



M2M system

To optimize the quality and equipment operation status without human intervention, made possible by enabling autonomous communication and exchange of information between various connected, production equipment.

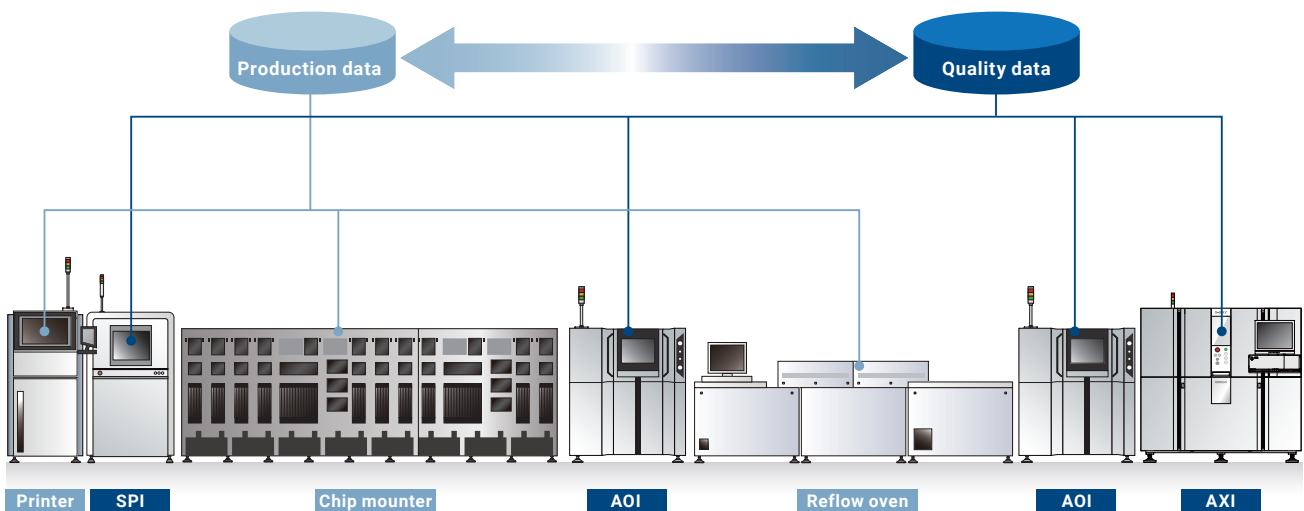

Preventing defects

Monitoring and reporting fluctuations in the measured values during production



Predictive detection of quality

Visualizing defect trends associated with chip mounter hardware such as heads and nozzles



Process quality trend analysis

M2M system requires the license linking to chip mounters.

Visualizing the quality

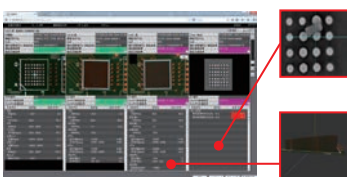

Process comparison

Patented



Displaying production status

Linking SPI/AOI/AXI system

Improving the first pass yield rate of the line

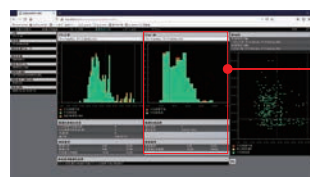

Automatically calculating SPI and pre-reflow AOI inspection criteria based on post-reflow AOI result data

Optimization of inspection criteria

The license from CKD is required.

Continuous manufacturing made possible by equipment monitoring and predictive maintenance

Equipped with Omron control hardware technology, this system allows real-time collection of information from all the IoT connected devices inside the inspection equipment. It allows the equipment status to be visualized, enabling predictive maintenance and quality traceability.



System configuration

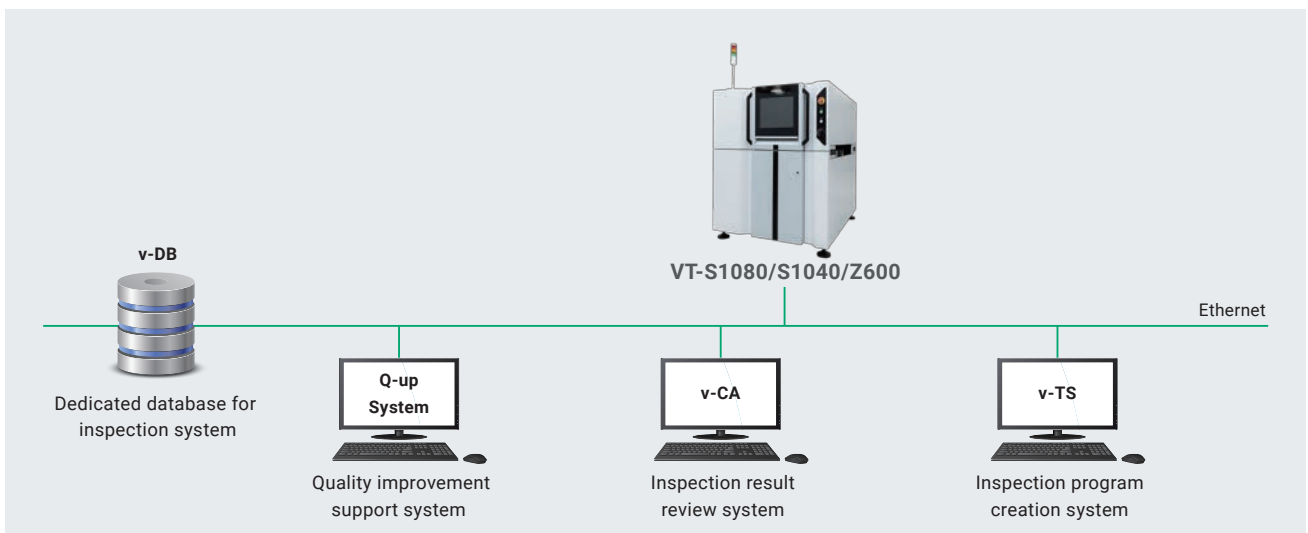

VT series product line-up

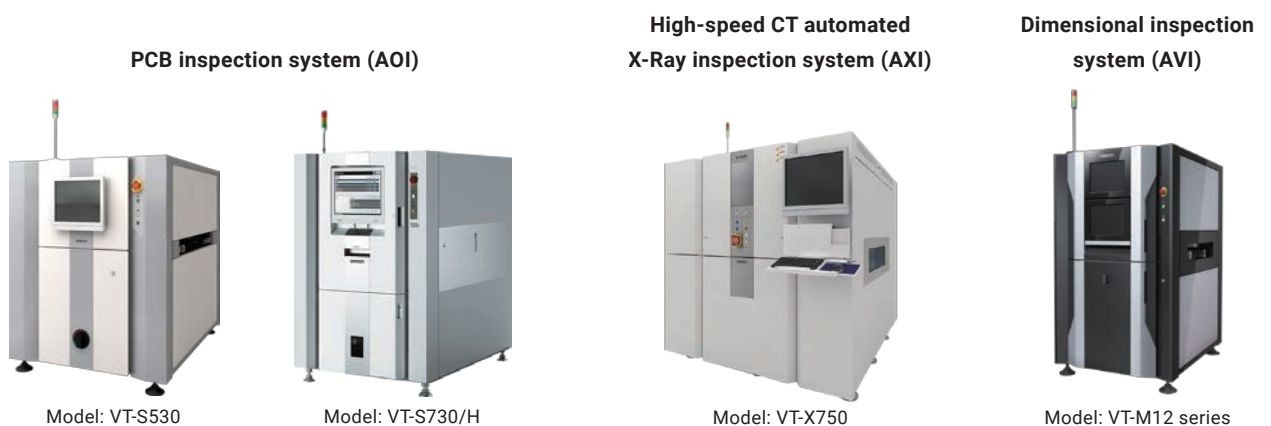

Outline dimensional drawing

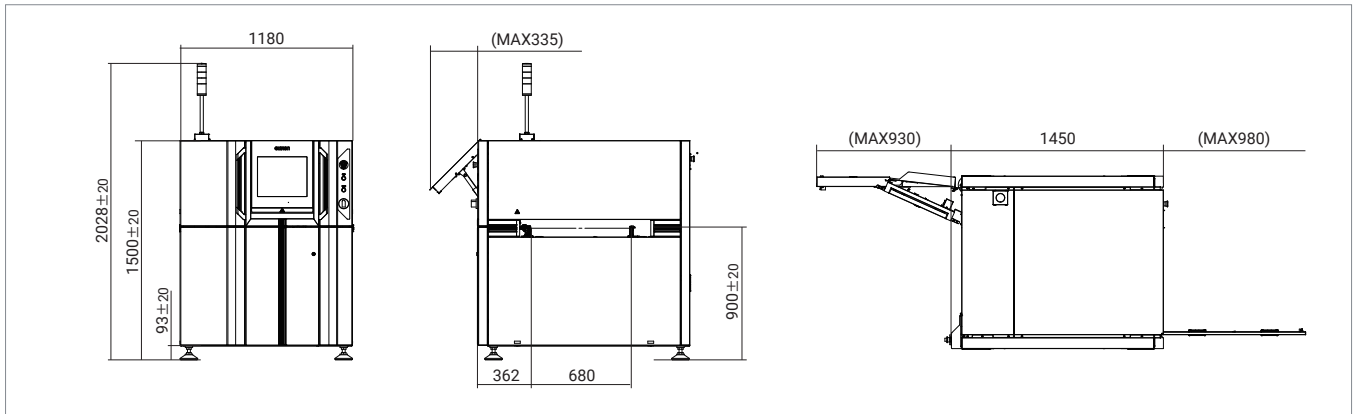

Hardware configuration / Functional specifications

Type	VT-S1080	VT-S1040	VT-Z600
Outer dimensions	1180(W) x 1450(D) x 1500(H)mm		
Weight	Approx. 1240Kg		
Power supply	200 to 240 V AC (Single phase); Voltage fluctuation range ±10%		
Rated power	2.0 kVA (Maximum current 10 A)		
Line height	900±20mm		
Air supply	Not required		
Operating temperature range	10~35°C		
Operating humidity range	35 to 80% RH (Non-condensing)		
Camera	Top	12Mpix	
	Angle	5Mpix	—
Resolution	Top	12.5μm	
	Angle	10μm	—
FOV	Top	50.0 x 37.5mm	
	Angle	25.9 x 19.4mm	—
Inspection principle	MDMC illumination+3D reconstruction through MPS	MDMC illumination+3D reconstruction through MPS*	MDMC illumination
Supported PCB size	Size	Single lane: 50(W) x 50(D)~510(W) x 680(D)mm Dual lane: 50(W) x 50(D)~510(W) x 330(D)mm	
	Thickness	0.4~4mm	
	Weight	4 Kg	
Clearance	Above the conveyor belt: 54 mm or less; Below the conveyor belt: 50 mm or less (Including board thickness/curvature/bend/part tolerance, etc.)		
Height measurement range	25.4mm		—
Inspection item	Component height, lift, tilt, missing or wrong component, wrong polarity, flipped component, OCR inspection, 2D code, component offset (X/Y/rotation), fillet (height/length, end joint width, wetting angle, side joint length), exposed land, foreign material, land error, lead offset, lead posture, lead presence, solder ball, solder bridge, distance between components, component angle	Missing or wrong component, wrong polarity, flipped component, OCR inspection, 2Dcode, component offset (X/Y/rotation), fillet (height/length, end joint width, wetting angle, side joint length)*9, exposed land, foreign material, land error, lead offset, lead posture, lead presence, solder ball, solder bridge, distance between components, component angle	

*8. Option for VT-S1040 *9. Only for the machine of post-reflow

- The application examples described in this brochure are for reference only. Please check the functions and safety of the equipment before using it
- When using in conditions or environments not described in this brochure, or for applications such as nuclear energy control systems, railroad systems, aviation systems, vehicles, combustion systems, medical equipment, amusement machines, safety equipment and others that could present a risk to life or property, Omron assumes no guarantee regarding the products except in the case of special product uses identified by Omron or with special agreement.
- When exporting (or providing to non-residents) this product, its parts or technology falling under the categories of export permissions or approved cargo (or technology) stipulated in the Foreign Exchange and Foreign Control Trade Law, an export permission and approval (or permission for service transaction) shall be necessary based on the same law.

OMRON Corporation

INDUSTRIAL AUTOMATION COMPANY INSPECTION SYSTEMS BUSINESS DIVISION SALES DEPARTMENT

Shinagawa Front Bldg. Conference 7F
2-3-13 Kounan Minato-ku Tokyo
108-0075 JAPAN
TEL +81-3-6718-3550 FAX:+81-3-6718-3553

OMRON INDUSTRIAL AUTOMATION (CHINA) CO., LTD.

F20,TowerA,NEO Building,6011ShennanAvenue,
Futian District, Shenzhen, Guangdong
518048, China
TEL: +86-755-8359-9028 FAX: +86-755-8359-9628

Omron AOI Business Europe, Omron Europe B.V.

Zilverenberg 2, 5234 GM's-Hertogenbosch, The Netherlands
TEL: +31 (0)736-481811 FAX: +31 (0)736-481879

OMRON AUTOMATION AMERICAS

2895 Greenspoint Parkway, Suite 200
Hoffman Estates, IL 60169 U.S.A
TEL:+1-847-843-7900 FAX:+1-847-843-7787

OMRON ELECTRONICS KOREA CO.,LTD.

21F, KyoboTower B Wing, 465, Gangnam-daero,
Seocho-gu, Seoul, Korea 137-920
TEL: +82-2-3483-7789 FAX: +82-2-3483-7788

OMRON ASIA PACIFIC PTE LTD

438A Alexandra Road #05-05/08 (Lobby 2)
Alexandra Technopark Singapore 119967
TEL:+65-6835-3011 FAX:+65-6835-2711

Authorized Distributor: