

MDM300 Sampling Options

To get the best possible performance from your MDM300 or MDM300 I.S., it is crucial to have appropriate sample conditioning for your measurement point. Options are available to cover all common sampling requirements – from verification of dry compressed air supplies, to the measurement of natural gas downstream of a glycol contactor.

Application Kits

Easi-fit and Compressed Air Kits

The Easi-fit kit is the ideal basic choice for applications where the sample pressure is elevated above ambient. It allows for indication and control of flow, when measuring either at atmospheric or at system pressure, by means of metering valves on the instrument inlet and outlet ports, and a flow meter.



The Compressed Air Kit has a similar configuration to the Easi-fit Kit, but with the addition of a particulate filter and Rp 1/4" fitting, commonly found in the compressed air industry. The fitting is connected to the filter inlet by a 2m length of PTFE tube, to allow for flexibility when coupling directly to compressed air systems.



Atmospheric Pressure & Sample Pump Kits

The Sample Pump Kit enables collection of gas samples from locations at atmospheric pressure, such as glove boxes. Powered by the MDM300 itself, the pump draws the gas through the instrument for measurement.

The Atmospheric Sampling Kit includes a particulate filter assembly to mount on to the MDM300 inlet, and flexible tubing to allow the pump to be remotely positioned. This Kit is not currently suitable for use with the MDM300 I.S.



SF6

The SF6 application kits are designed to provide a straightforward method for sampling Sulphur Hexafluoride quench gas from high voltage switchgear. The kit is fitted with a Dilo connection (either DN8 or DN20), which allows it to be coupled to the sample ports fitted to the switchgear.

It also features a rectus quick release connection on the outlet for self-sealing the instrument after a gas capture system has been fitted. Also available is a gas capture bag, which can connect to this outlet to facilitate quick collection of the sample, for either recycling or disposal.

Medical Gas Kit

Clean medical gases are used in a number of applications in hospitals. Their purity and cleanliness is crucial, along with the absence of liquid water, for avoiding corrosion or growth of organic organisms in the equipment used to deliver them. The medical gas sampling system is designed for direct sampling of clean medical gases to ensure their dryness, by connecting to the bulkhead of the system using a standard 3/8" NGS probe.

Panel-Mount System: MDM300-SAM-PNL

The panel mounted system is a complete system for portability when a single filter type is required. It allows measurement of samples up to 300 barg at either system or atmospheric pressure. Setting the required flow rate is simplified by the presence of bypass arrangement. As the system is mounted integrally with the instrument to a panel, the user only needs to connect an inlet and a vent, rather than assembling the system at the point of measurement. Also available is a solid transport case, so the entire panel can be protected for storage/transit etc.

Highlights

- MDM300 is mounted onto sampling system, so no installation is required to make a measurement – connect the system to the sample collection point and measure
- Gauge for monitoring sample pressure and flow control valves included
- Simple access for maintenance and replacement of filter elements
- Optional transportation case, to protect panel against damage in transit



Flow Diagram

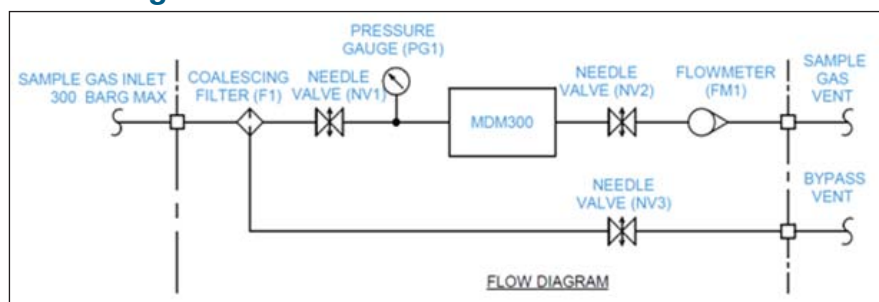

Technical Specifications

Operating Conditions	
Maximum Inlet/ Sample Pressure	300 barg max
Operating Environment	-20 to +50°C
Storage/ Transport Temperature	-20 to +50°C
Mechanical Specifications	
Mounting Arrangement	Panel mounted on AISI 316
IP/ NEMA Rating	None
Gas Connections	Choice of Swagelok tube connectors
Flow Measurement	Dwyer Flowmeter
Flow Control	Swagelok® metering valves
Filters	Choice of: particulate, coalescing, and glysob filters
Gas Wetted Materials	AISI 316 and Viton; other materials on request
Dimensions	400 x 300 x 150mm
Weight	5kg

Michell Instruments, Inc 319 Newburyport Turnpike, Suite 207, Rowley, MA 01969

Tel: 978 484 0005, Fax: 978 843 7669, Email: us.info@michell.com, Web: www.michell.com/us

Michell Instruments adopts a continuous development programme which sometimes necessitates specification changes without notice.
Issue no: MDM300 I.S. Sampling Options_97329_V3_US_0517